

# **FILTER SYSTEMS AND WATER TREATMENT**

With the environment in mind

Band filter  
Compact band filter  
Magnetic separator  
Filter housing  
Oil separator  
Masterclean  
Mobile filter unit  
Machine connections  
Piston pump  
Coolant saver  
Filter paper



## One-stop-shop for industrial filtration and cleaning systems

---

### Design – Develop – Deliver

At FILCO we take great pride in controlling the entire process of designing, manufacturing, installing and servicing your industrial cleaning solution. Our dedicated employees and loyal subcontractors constitute a comprehensive and competent organization focused solely on customer satisfaction. Our own R&D and production facilities deliver the solutions you need, and our service organization keep them up and running, around the world and around the clock.

### We get the job done

In addition to manufacturing our own standard and custom solutions we also have our own production of filters, and we carry all other necessary parts and accessories in stock. Our in-house experts are always standing by to assist you, whenever you need help.

### We've got you covered

Our service organization is spread out both nationally and internationally. No matter where you are, and where you need us, we are never far away. Our broad expertise extends across industries, borders and technologies including magnet cleaning systems and other advanced solutions.

# CONTENT

**Why invest? 7**

Read about why filtration benefits both budget and environment in a modern production.

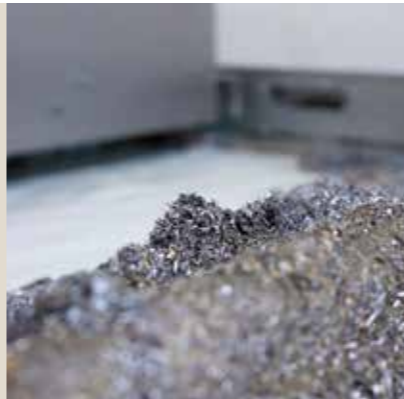

**Band filter UF 8**

FILCO's high quality band filters are produced in stainless steel. They are mainly used for filtration of non-explosive fluids e.g. coolants, oils and process fluids from cleaning systems and CNC-machines.



**Band filter TM 10**

High quality band filter designed for large volumes and heavy-duty contamination. Build with a belt-conveyor which conveys forward the filter paper.



**Band filter TMP 12**

Band filter developed for applications with highly corrosive fluids like salt water and acids. Based on the TM design - build in polypropylene.



**Band filter TME 14**

High quality endless band filter designed for large volumes and heavy-duty contamination. Build with an endless-band system which consumes no filter paper.



**Compact band filter 16**

Cost effective band filter for filtration of coolants, oils and process fluids. The compact band filter is a small filter that does not compromise on quality.



**Magnetic separator 18**

Magnetic separator that is easy to integrate into existing equipment and is mainly used for mounting directly on a band filter or similar.



**Filter housing 20**

We offer a wide range of filter housings in stainless steel for both filter bags- and cartridges.



**Oil separator 22**

Innovative high-quality oil separator constructed in stainless steel. The oil separator is designed with a two or four-chamber labyrinth system which ensures efficient separation.



**Masterclean 24**

Reduce your operating costs significantly, extend the lifespan of your tools and help the environment with a central filtration system from us.



**Mobile filter unit 28**

A Mobile Filter Unit can easily be moved to and between the individual machines in a production. It is easy to connect and operate.



**Connection 30**

The machine connections are designed for our central filtration systems but can easily be implemented for similar systems from other manufactures.



**Piston pump 32**

Our specially developed piston pump with stainless steel housing and gear motor ensures a gentle treatment of the fluid to ensure optimal separation of free oils.



**Coolant saver 34**

Our coolant saver is manufactured and developed for continuous removal of small quantities of fluids from containers and tanks.

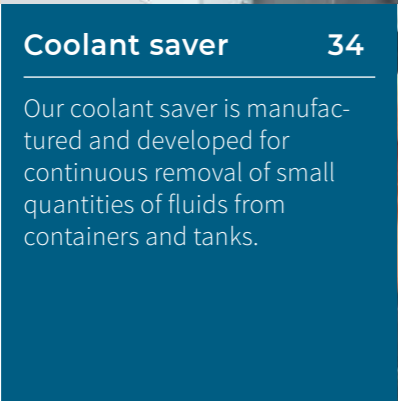

**Filter paper 36**

We have a large stock of filter paper for direct delivery. Therefore you will experience no challenges with downtime and have no need for a large internal stock.



# Precision cleaning

## What we do

We design, develop and deliver fluid cleaning and filtration equipment and services for demanding tasks and industries. Our experienced experts will make sure that your filtration system is installed and implemented effectively, and our extensive service and accessories programme will keep it up and running. Our filtration systems will also help you reduce operating costs and improve both your working environment and environmental profile of your company.

## How we do it

Our wide range of industry leading standard solutions will cover most demands within most industries. Furthermore our extensive experience allows us to modify existing equipment and design custom solutions for any special task you might have. FILCO is founded on customer focus, and our aim is to add value to your business through sustainable and user-friendly solutions.

## Where we come from

FILCO was founded by Steffen Myrvoll who has 30 years of experience in industrial filtration equipment and solutions. The fundamental purpose of the company is to be a one-stop-shop for precision cleaning equipment. Not only do we design, produce and deliver both standard and custom solutions. We also provide global installation and maintenance and keep all vital parts and accessories in stock to ensure quick delivery and minimum down time for our customers.

# Filtration benefits both budget and environment

A proper and well-designed filtration system will remove dirt and residue from coolants and process fluids prolonging the lifespan without damaging tools and other production equipment. This results in a number of both economic and environmentally related advantages.

Filtering your coolants and process fluids will obviously reduce costs for new fluids as well as for disposal. It also reduces costs for maintenance and replacing tools and other production equipment which is subject to wear and tear when it comes into contact with fluids containing e.g. chips, magnetic particles and graphite.

Filtration systems are also available to remove oil and grease from fluids preventing bacterial growth

and for removing dust, hair, paint, resins and other hard particles.

Safety and working environment are dramatically improved as workers are no longer required to constantly handle and refill fluids manually. This also reduces man hours for manual refilling of fluids. Furthermore, filtrating fluids will contribute positively to the environmental profile of your business.

A filtration system is suitable for most industries using coolants and process fluids. From tool shops to food and medical. At FILCO we not only design and deliver customized filtration systems. We also produce our own filters including our unique polypropylene filters, which can be used for filtrating acids and salt water.

## Filtration systems adds value to your business by:

- Reducing costs for refilling and disposing of coolants and process fluids
- Prolonging the lifespan of tools and other equipment due to less wear and tear
- Reducing manual handling of chemicals and other dangerous fluids
- Reducing man hours for manual refilling of fluids
- Improving the overall environmental profile of your business

To learn more, feel free to contact us any time at [info@filco.dk](mailto:info@filco.dk) or +45 8750 9899



### Chips and particles

The filtration systems removes metal- and plastic chips and particles to improve the lifespan of the process fluid and machining tools.



### Oil and grease

Efficiently separates demulsifying oil and grease to improve lifespan of the process fluid and prevent bacterial growth.



### Magnetic particles and graphite

The filtration systems can be equipped with a magnetic separator to remove graphite, iron oxides and other magnetic particles from the process fluid.



### General contamination

Dust, hair, paint, resins and other hard particles can be removed in our filtration systems which can filtrate down to 5 micron.

# BAND FILTER UF

Our high quality band filters are produced in stainless steel. They are mainly used for filtration of coolants, oils and process fluids from cleaning systems and CNC-machines.

The band filters are produced in different sizes depending on customer needs and can filtrate up to 600 liters per minute. The band filters uses filter paper which can be acquired in different types depending on the application. The band filters can be used separately as stand-alone-units or as a build-in unit for larger filtration systems.

## Applications:

- Coolant
- Process fluid
- Oil
- Water treatment
- Sewage

## Extra options:

- Filter paper
- Stainless steel support frame
- Polypropylene or stainless steel container
- Tank unit
- Construction in AISI 316 / EN 1.4401



MODEL	UF 250	UF 500	UF 700	UF 1000	UF 2000
Length	965 mm	965 mm	965 mm	965 mm	1965 mm
Width	450 mm	700 mm	900 mm	1200 mm	1200 mm
Inlet height	538 mm	538 mm	538 mm	538 mm	657 mm
1 1/2" inlet	1 pcs.	2 pcs. (200 mm C-C)	2 pcs. (300 mm C-C)	2 pcs. (400 mm C-C)	2 pcs. (400 mm C-C)
Flow capacity	100 L/min	150 L/min	250 L/min	350 L/min	600 L/min
Power supply	1x230V / 3x400V + N + PE - 50 Hz	1x230V / 3x400V + N + PE - 50 Hz	1x230V / 3x400V + N + PE - 50 Hz	1x230V / 3x400V + N + PE - 50 Hz	1x230V / 3x400V + N + PE - 50 Hz
Control current	24 VDC	24 VDC	24 VDC	24 VDC	24 VDC
Protection grade	IP54	IP54	IP54	IP54	IP54

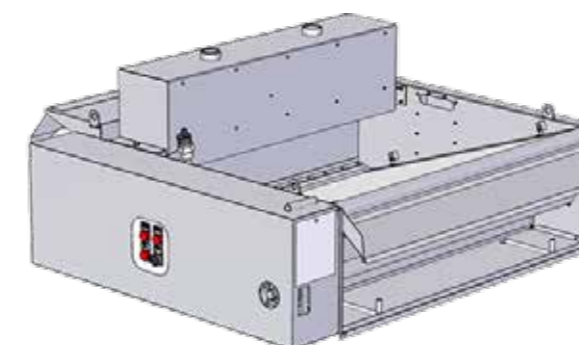
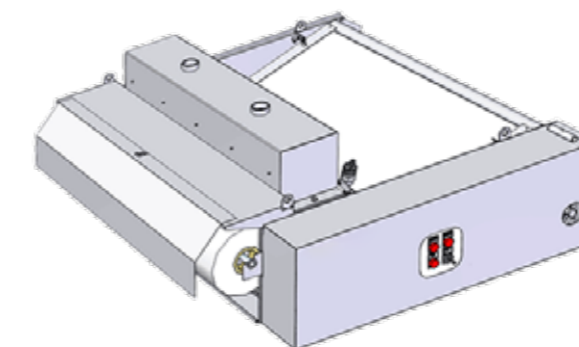

DRAWING:  
UF 500

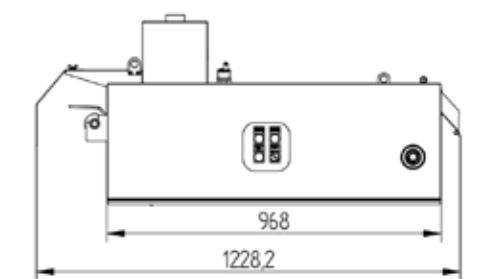
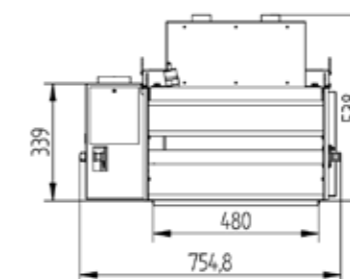
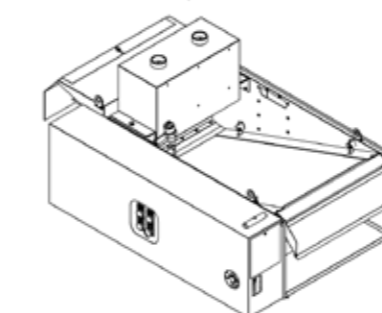

- ✓ **100% stainless steel construction**  
Produced in AISI 304 / EN 1.4301.
- ✓ **Frequency regulated**  
The frequency regulated gear motor enables a smooth and slow movement of the of the filter paper, which ensures the permanent build-up of a filter cake.
- ✓ **Analog control cabinet**  
The band filter has a control cabinet with lamps to provide information about filter paper status and alarm status.
- ✓ **Level sensor**  
The digital level sensor ensures precise use of filter paper. This also makes the filter very efficient because of the continuously high fluid pressure. This reduces operation costs and results in better filtration.
- ✓ **Paper sensors**  
The band filter has built-in sensors for low paper and full paper.
- ✓ **Overflow surveillance**  
The band filter has build-in overflow surveillance. In case of overflow the bypass duct ensures that the fluid is lead through the filter instead of overflowing the filter.
- ✓ **CE - EU Machinery Directive**  
The band filter is produced in Denmark in conformity with the EU Machinery Directive.

# BAND FILTER TM

High quality band filter designed for large volumes and heavy-duty contamination. Build with a belt-conveyor which conveys forward the filter paper. The band filter TM is available for volumes up to 3.000 L/min.



## Extra options:

- Filter paper
- Stainless steel support frame
- Polypropylene or stainless steel container
- Tank unit
- Available in AISI 316 / EN 1.4401

MODEL	TM 40	TM 80	TM 140	TM 180	TM 240	TM 360	TM 550
Flow capacity	216 L/min	450 L/min	750 L/min	1000 L/min	1500 L/min	2000 L/min	3000 L/min
Protection grade	IP54	IP54	IP54	IP54	IP54	IP54	IP54
Control current	24 VDC	24 VDC	24 VDC	24 VDC	24 VDC	24 VDC	24 VDC
Power supply	1x230V / 3x400V + N + PE - 50 Hz	1x230V / 3x400V + N + PE - 50 Hz	1x230V / 3x400V + N + PE - 50 Hz	1x230V / 3x400V + N + PE - 50 Hz	1x230V / 3x400V + N + PE - 50 Hz	1x230V / 3x400V + N + PE - 50 Hz	1x230V / 3x400V + N + PE - 50 Hz
Paper width	500 mm	1000 mm	1000mm	1000 mm	1000 mm	1500 mm	1500 mm
Filter area	0,4 m <sup>2</sup>	0,8 m <sup>2</sup>	1,4 m <sup>2</sup>	1,8 m <sup>2</sup>	2,4 m <sup>2</sup>	3,6 m <sup>2</sup>	5,5 m <sup>2</sup>

DRAWING:  
TM 240

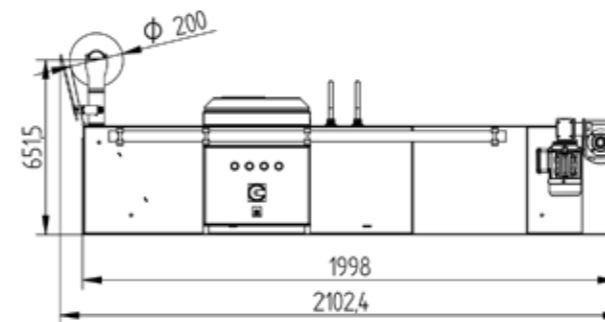
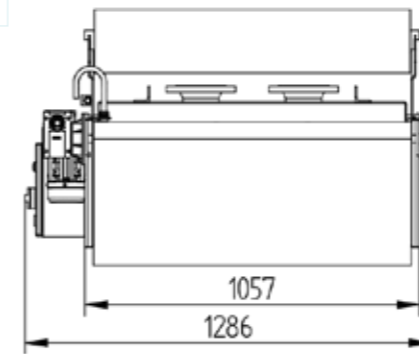

- ✓ **100% stainless steel construction**  
Produced in AISI 304 / EN 1.4301.
- ✓ **High capacity**  
Due to its deep-bed construction this filter can handle high volumes of fluid.
- ✓ **Frequency regulated**  
The frequency regulated gear motor enables a smooth and slow movement of the of the filter paper, which ensures the permanent build-up of a filter cake.
- ✓ **Analog control cabinet**  
The band filter has a control cabinet with lamps to provide information about filter paper status and alarm status.
- ✓ **Level sensor**  
The digital level sensor ensures precise use of filter paper. This also makes the filter very efficient because of the continuously high fluid pressure. This reduces operation costs and results in better filtration.
- ✓ **Paper sensors**  
The band filter has built-in sensor for low paper.
- ✓ **Overflow surveillance**  
The band filter has build-in overflow surveillance. In case of overflow the bypass duct ensures that the fluid is lead through the filter instead of overflowing the filter.

# BAND FILTER TMP

Developed for applications with highly corrosive fluids like salt water and acids. Based on the TM design - build in polypropylene.

The band filter is made in polypropylene on all surfaces in contact with the fluid and is using filter paper for efficient filtration.

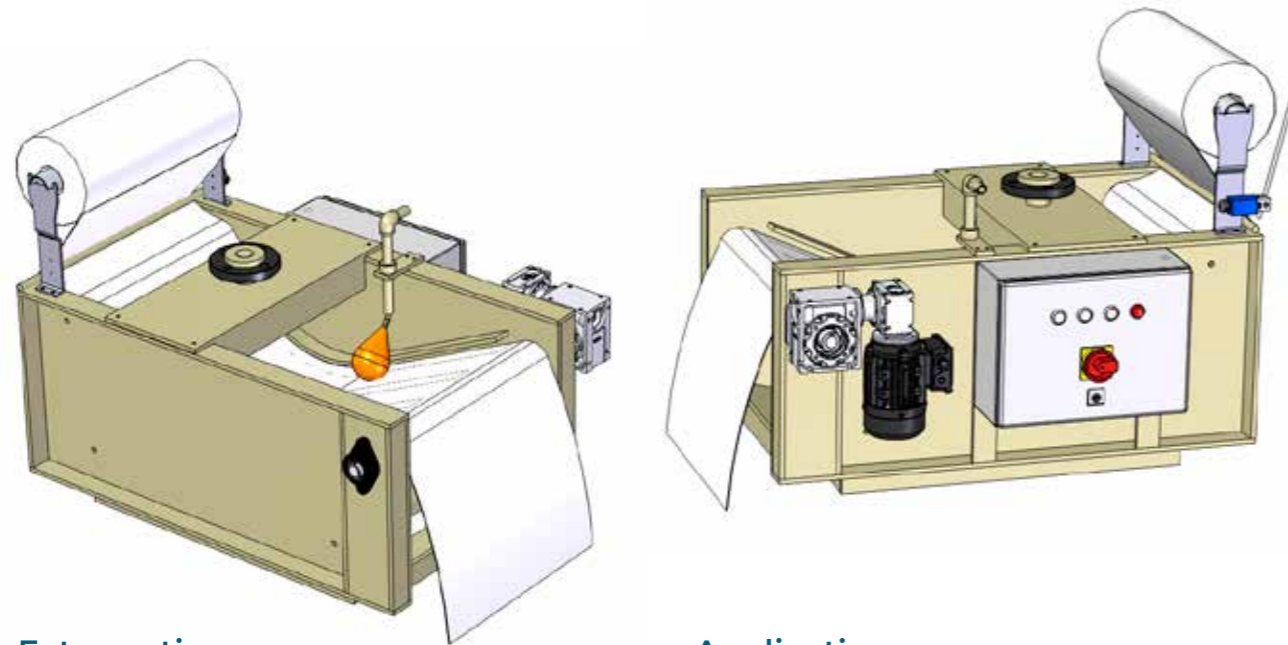

## Extra options:

- Filter paper
- Stainless steel support frame
- Polypropylene container
- Tank unit

## Applications:

- Salt water
- Highly corrosive fluids
- Acids

MODEL	TMP 40	TMP 80	TMP 140	TMP 180	TMP 240	TMP 360	TMP 550
Flow capacity	216 L/min	450 L/min	750 L/min	1000 L/min	1500 L/min	2000 L/min	3000 L/min
Protection grade	IP54	IP54	IP54	IP54	IP54	IP54	IP54
Control current	24 VDC	24 VDC	24 VDC	24 VDC	24 VDC	24 VDC	24 VDC
Power supply	1x230V / 3x400V + N + PE - 50 Hz	1x230V / 3x400V + N + PE - 50 Hz	1x230V / 3x400V + N + PE - 50 Hz	1x230V / 3x400V + N + PE - 50 Hz	1x230V / 3x400V + N + PE - 50 Hz	1x230V / 3x400V + N + PE - 50 Hz	1x230V / 3x400V + N + PE - 50 Hz
Paper width	500 mm	1000 mm	1000 mm	1000 mm	1000 mm	1500 mm	1500 mm
Filter area	0,4 m <sup>2</sup>	0,8 m <sup>2</sup>	1,4 m <sup>2</sup>	1,8 m <sup>2</sup>	2,4 m <sup>2</sup>	3,6 m <sup>2</sup>	5,5 m <sup>2</sup>

- ✓ **Polypropylene construction**  
Designed for highly corrosive fluids and only a few parts like gear motor, filter paper holder and electrical cabinet are not polypropylene.
- ✓ **High capacity**  
Due to its deep-bed construction this filter can handle high volumes of fluid.
- ✓ **Frequency regulated**  
The frequency regulated gear motor enables a smooth and slow movement of the of the filter paper, which ensures the permanent build-up of a filter cake.
- ✓ **Analog control cabinet**  
The band filter has a control cabinet with lamps to provide information about filter paper status and alarm status.
- ✓ **Level sensor**  
The digital level sensor ensures precise use of filter paper. This also makes the filter very efficient because of the continuously high fluid pressure. This reduces operation costs and results in better filtration.
- ✓ **Paper sensors**  
The band filter has built-in sensor for low paper.
- ✓ **Overflow surveillance**  
The band filter has build-in overflow surveillance. In case of overflow the bypass duct ensures that the fluid is lead through the filter instead of overflowing the filter.

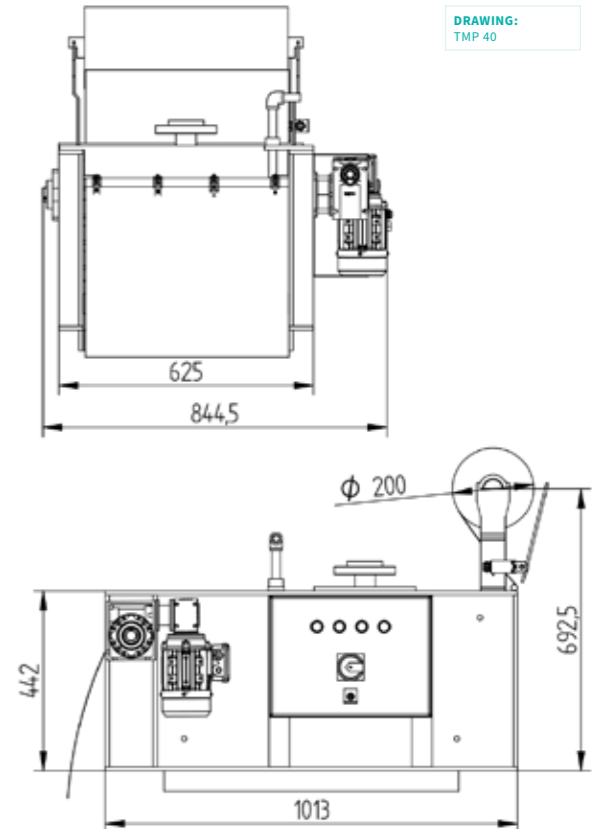

# BAND FILTER TME

High quality endless band filter designed for large volumes and heavy-duty contamination. Build with an endless-band system which consumes no filter paper. The endless band filter TME is available for volumes up to 3.000 L/min.



This band filter does not use filter paper for the filtration process. Instead it uses an endless band which is cleaned by either brushes, high compressed air and/or fluid depending on application.

The endless band is available in different finenesses from 30-400 microns.

### Extra options:

- Stainless steel support frame
- Polypropylene or stainless steel container
- Tank unit
- Available in AISI 316 / EN 1.4401

MODEL	TME 40	TME 80	TME 140	TME 180	TME 240	TME 360	TME 550
Flow capacity	216 L/min	450 L/min	750 L/min	1000 L/min	1500 L/min	2000 L/min	3000 L/min
Protection grade	IP54	IP54	IP54	IP54	IP54	IP54	IP54
Control current	24 VDC	24 VDC	24 VDC	24 VDC	24 VDC	24 VDC	24 VDC
Power supply	1x230V / 3x400V + N + PE - 50 Hz	1x230V / 3x400V + N + PE - 50 Hz	1x230V / 3x400V + N + PE - 50 Hz	1x230V / 3x400V + N + PE - 50 Hz	1x230V / 3x400V + N + PE - 50 Hz	1x230V / 3x400V + N + PE - 50 Hz	1x230V / 3x400V + N + PE - 50 Hz
Band width	500 mm	1000 mm	1000 mm	1000 mm	1000 mm	1500 mm	1500 mm
Filter area	0,4 m <sup>2</sup>	0,8 m <sup>2</sup>	1,4 m <sup>2</sup>	1,8 m <sup>2</sup>	2,4 m <sup>2</sup>	3,6 m <sup>2</sup>	5,5 m <sup>2</sup>



- ✓ **100% stainless steel construction**  
Produced in AISI 304 / EN 1.4301.
- ✓ **High capacity**  
Due to its deep-bed construction this filter can handle high volumes of fluid.
- ✓ **Endless band filter**  
This band filter is not using any form of filter paper which means there is no consumables during operation.
- ✓ **Self-cleaning**  
The band filter cleans the endless band with either brushes, high compressed air and/or fluid depending on application.
- ✓ **Frequency regulated**  
The frequency regulated gear motor enables a smooth and slow movement of the endless

band, which ensures the permanent build-up of a filter cake.

- ✓ **Analog control cabinet**  
The band filter has a control cabinet with lamps to provide information about overflow and alarm status.
- ✓ **Level sensor**  
The digital level sensor ensures precise use of the endless band. This also makes the filter very efficient because of the continuously high fluid pressure. This reduces operation costs and results in better filtration.
- ✓ **Overflow surveillance**  
The band filter has build-in overflow surveillance. In case of overflow the bypass duct ensures that the fluid is lead through the filter instead of overflowing the filter.



# COMPACT BAND FILTER KF

**Cost effective band filter for filtration of coolants, oils and process fluids. The compact band filter is a small filter that does not compromise on quality.**

The compact band filters are produced in different sizes depending on customer needs and can filtrate up to 150 liters per minute. The compact band filters uses filter paper which can be acquired in different types depending on the application. The compact band filters can be used separately as stand-alone-units or as a build-in unit for larger filtration systems.

The compact band filter is a small filter without a control cabinet and paper sensor. Due to fact that the gear motor is directly controlled by the float, the need for a control cabinet is eliminated. This makes the compact band filter a highly attractive low cost solution.

## Applications:

- Coolant
- Process fluid
- Oil
- Water treatment
- Sewage



MODEL	KF 250	KF 500	KF 700
Flow capacity	50 L/min	100 L/min	150 L/min
Power supply	1x230V / 3x400V + N + PE 50 Hz	1x230V / 3x400V + N + PE 50 Hz	1x230V / 3x400V + N + PE 50 Hz
Control current	24 VAC	24 VAC	24 VAC
Protection grade	IP54	IP54	IP54

## Extra options:

- Filter paper
- Stainless steel support frame
- Tank unit
- Construction in AISI 316 / EN 1.4401
- Control cabinet
- Paper sensor
- Overflow sensor
- Return pump / pump station



✓ **100% stainless steel construction**  
Produced in AISI 304 / EN 1.4301.

✓ **Low cost solution**  
A low cost compact band filter for efficiently filtering of low volumes of fluid. The filter runs without a control cabinet and paper sensors making this filter a highly attractive low cost solution.

✓ **Level sensor**  
The level float directly controls the motor making an electrical cabinet unnecessary.

✓ **Overflow**  
In case of overflow the bypass duct ensures that the fluid is lead through the filter instead of overflowing the filter.

✓ **Compact size**  
Due to its small size this filter is suitable for mobile solutions or confined spaces.

✓ **CE - EU Machinery Directive**  
The band filter is produced in Denmark in conformity with the EU Machinery Directive.

# MAGNETIC SEPARATOR

**Magnetic separator that is easy to integrate into existing equipment and is mainly used for mounting directly on a band filter or similar.**

Magnetic separator for removing iron oxide, graphite and magnetic particles from process fluids, oil and coolants. The magnetic separator comes with a very powerful magnet and has a large surface area which makes it extremely effective in removing the magnetic particles.

It comes standard in stainless steel including a manifold for distributing the fluid and a dirt tray. Ready for installation.

The magnetic separator is available in a special edition that can be used for acid and corrosive fluids.

## Applications:

- Coolant
- Process fluid
- Oil
- Water treatment
- Sewage



MODEL	MS-100	MS-200	MS-300	MS-400	MS-500	MS-600	MS-700	MS-800
Coolant	100 L/min	200 L/min	300 L/min	400 L/min	500 L/min	600 L/min	700 L/min	800 L/min
Oil	80 L/min	160 L/min	240 L/min	320 L/min	400 L/min	480 L/min	560 L/min	640 L/min
Width	171 mm	276 mm	381 mm	486 mm	591 mm	696 mm	801 mm	906 mm
Weight	56 kg	71 kg	86 kg	102 kg	117 kg	133 kg	148 kg	163 kg
Power supply	3x400V +PE 50 Hz	3x400V +PE 50 Hz	3x400V +PE 50 Hz	3x400V +PE 50 Hz	3x400V +PE 50 Hz	3x400V +PE 50 Hz	3x400V +PE 50 Hz	3x400V +PE 50 Hz

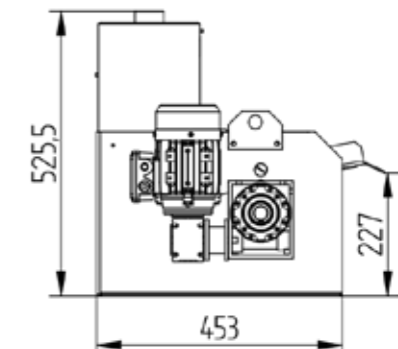
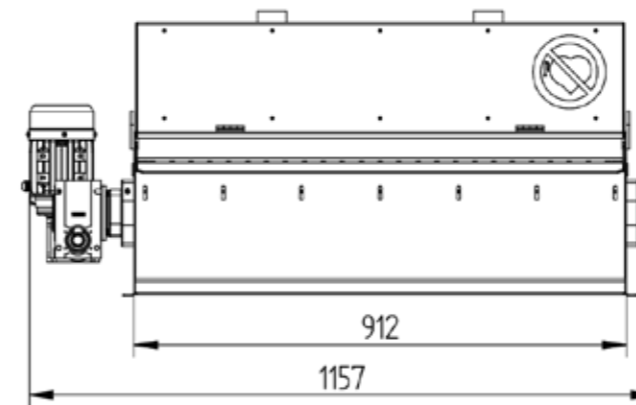

DRAWING:  
MS-800



- ✓ **Fluid manifold**  
Magnetic separator has a manifold for even distribution of the fluid which ensures the best result.
- ✓ **Large magnetic surface**  
Due to the design we have a large magnetic surface that improves filtration.
- ✓ **Stainless steel construction**  
The magnetic separator is supplied in stainless steel which makes it unique and at the same time we can easily adapt it to work with acid.
- ✓ **CE - EU Machinery Directive**  
The magnetic separator is produced in Denmark in conformity with the EU Machinery Directive.

# FILTER HOUSING

We offer a wide range of filter housings in stainless steel for both filter bags- and cartridges.

The filter housings are constructed following general industrial standards, and can be offered including filtration pumps. The main part of our filter housings are used in cleaning- and filtration systems for treatment of process fluids.



MODEL	FILCO P04	FILCO P01	FILCO P02
Description	Filter housing with manometer	Filter housing with manometer	Filter housing with manometer
Material	AISI 304/316	AISI 304/316	AISI 304/316
Filter	Bag - Ø100×380 mm	Bag - Ø180×430 mm	Bag - Ø180×810 mm

✓ **100% stainless steel construction**  
Produced in both AISI 304 / EN 1.4301 and AISI 316 / EN 1.4401.

✓ **Pressure gauge**  
All filter housings can be delivered with a pressure gauge for measuring pressure inside the filter housing.

✓ **Extra options**  
We offer a wide range of extra options, like pumps, filter bags, cartridges, magnets etc.

✓ **Industrial standards**  
The filter housings are produced in accordance to general industrial standards, which means filter bags- and cartridges are available worldwide.

# OIL SEPARATOR

**Innovative high-quality oil separator constructed in stainless steel. The oil separator is designed with a two or four-chamber labyrinth system which ensures efficient separation.**

The surface oils are sucked into the oil separator by means of a self-levelling suction head. This is placed in the tank where the unwanted oils are to be removed from. The labyrinth system ensures optimal conditions for separation of the fluids. Due to our in-house developed piston pump further mixture of the fluids is prevented as the pump handles the fluid very gently. The oil separator ensures that the process fluid is always free of unwanted oils, which effects operation and process fluid lifespan.



## Applications:

- Tank units from washing systems
- Machining centers
- Process fluid tanks
- Waste water treatment

MODEL	OS-S2	OS-Q2
Flow capacity	120 L/h	120 L/h
Separation chambers	2	4
Power supply	1x230V / 3x400V + PE 50 Hz	1x230V / 3x400V + PE 50 Hz
Length	305 mm	500 mm
Width	260 mm	600 mm
Height	400 mm	470 mm
Weight	7 kg	20 kg

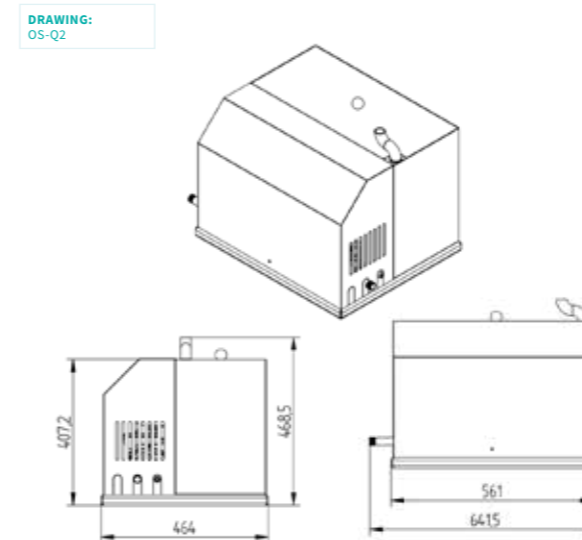
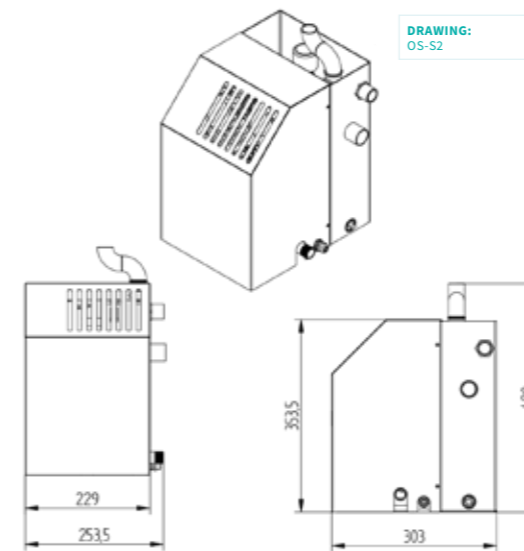

- ✓ **Continuous draining of surface oils**  
The oil separator ensures continuous draining of oils.
- ✓ **Flexible solution**  
Compact and flexible solution which can be used stationary and as a mobile unit.
- ✓ **Unique piston pump**  
The in-house developed piston pump with stainless steel housing ensures efficient flow and gentle handling of the fluid.
- ✓ **Suction head included**  
The oil separator includes a suction head ready for installation into tank units. The suction head floats at the surface where it creates suction that causes a natural flow to the suction head.
- ✓ **Chamber system**  
The oil separator has either a two or a four-chamber labyrinth system, which ensures efficient separation of oils.
- ✓ **Extends the lifespan of process fluids**  
Efficient separation of oils extends the lifespan of the process fluids and lowers costs.
- ✓ **100% stainless steel construction**  
Produced in AISI 304 / EN 1.4301.
- ✓ **CE – EU Machinery Directive**  
The oil separator is produced in Denmark in conformity with the EU Machinery Directive.



# MASTERCLEAN

**Reduce your operating costs significantly, extend the lifespan of your tools and help the environment with a central filtration system from us.**

Our custom made central filtration systems for efficient filtration of coolants and process fluids made at our factory in Denmark, are available either as a bypass or full flow system constructed in powerful stainless steel with bandfilter, oil separator, pumps, level control and control cabinet. A centralized system is a complete solution with user-friendly control including monitoring and alarms as well as the possibility of SMS warnings and a wide range of extra options.

## Applications:

- Coolant
- Process fluid
- Oil
- Water treatment
- Sewage

## Extra options:

- Chiller
- Magnetic separator
- Automatic dosing systems
- Snail conveyor for dirt
- Filter housings
- Filter paper
- Double-walled tank
- Insulated tank
- Collecting tray according to Water Resources Act (WHG)



MODEL	MC 1000	MC 2000	MC 3000	MC 4500	MC 6000	MC 8000	MC 10000	MC 12000	MC 14000
Tank volume	1000 L	2000 L	3000 L	4500 L	6000 L	8000 L	10000 L	12000 L	14000 L
Band filter	UF 500	UF 1000	UF 1000	UF 1000	UF 2000	UF 2000	UF 2000	UF 2000	UF 2000
Oil separator	OS-Q2	OS-Q2	OS-Q2	OS-Q2	OS-Q2	OS-Q2	OS-Q2	OS-Q2	OS-Q2
Power supply	3x400V + N + PE 50 Hz	3x400V + N + PE 50 Hz	3x400V + N + PE 50 Hz	3x400V + N + PE 50 Hz	3x400V + N + PE 50 Hz	3x400V + N + PE 50 Hz	3x400V + N + PE 50 Hz	3x400V + N + PE 50 Hz	3x400V + N + PE 50 Hz
Labyrinth system	—	Yes	Yes	Yes	Yes	Yes	Yes	Yes	Yes

### ✓ 100% stainless steel construction

Produced in AISI 304 / EN 1.4301.

### ✓ Band filter

A hydrostatic band filter for filtration of contaminants, particles and chips from the process fluid is standard.

### ✓ Reduce operation cost significantly

A centralized filtration system can reduce operation costs of up to 5.300 euro pr. year on each connected CNC-machine.

### ✓ Oil separator

Our innovative oil separator with four-chamber system is build into the filtration system.

### ✓ Higher overall efficiency

The reduced manpower needed for maintaining the CNC-machines and more production hours pr. machine improves efficiency in the whole production.

### ✓ Monitoring and control

The centralized filtration systems is delivered with complete monitoring systems including alarms and possibility for SMS-service.

### ✓ Custom made solution

The centralized filtration systems are always produced according to customer specific needs.

### ✓ Effective continuous filtration

The filtration systems ensures continuous filtering of the process fluid during production.

### ✓ Automatic waterfilling

The filtration system is automatically controlling the water level using a level sensor and magnetic valves.

### ✓ CE – EU Machinery Directive

The centralized system is produced in Denmark in conformity with the EU Machinery Directive.

# MASTERCLEAN

Experience the Masterclean central filtration systems in the pictures below, where you can find two installations of the filtration system in operation at some of our many satisfied customers.



**ALSTED METAL**  
Per Alsted Christensen  
Owner



The central filtration system for filtering coolant.



We provide you with a turnkey solution including installation work such as piping.

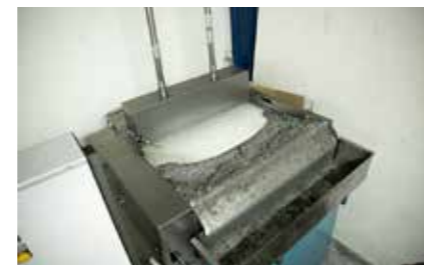

Hydrostatic band filter for filtering particles and metal chips from the coolant.



**BRANDT METAL INDUSTRY**  
Johnny Brandt  
Owner



The turning department at Brandt Metal Industry with the central filtration system.



The central filtration system for filtering coolant.



Our high-end external machine connection for ensuring efficient flow and exchange of coolant.

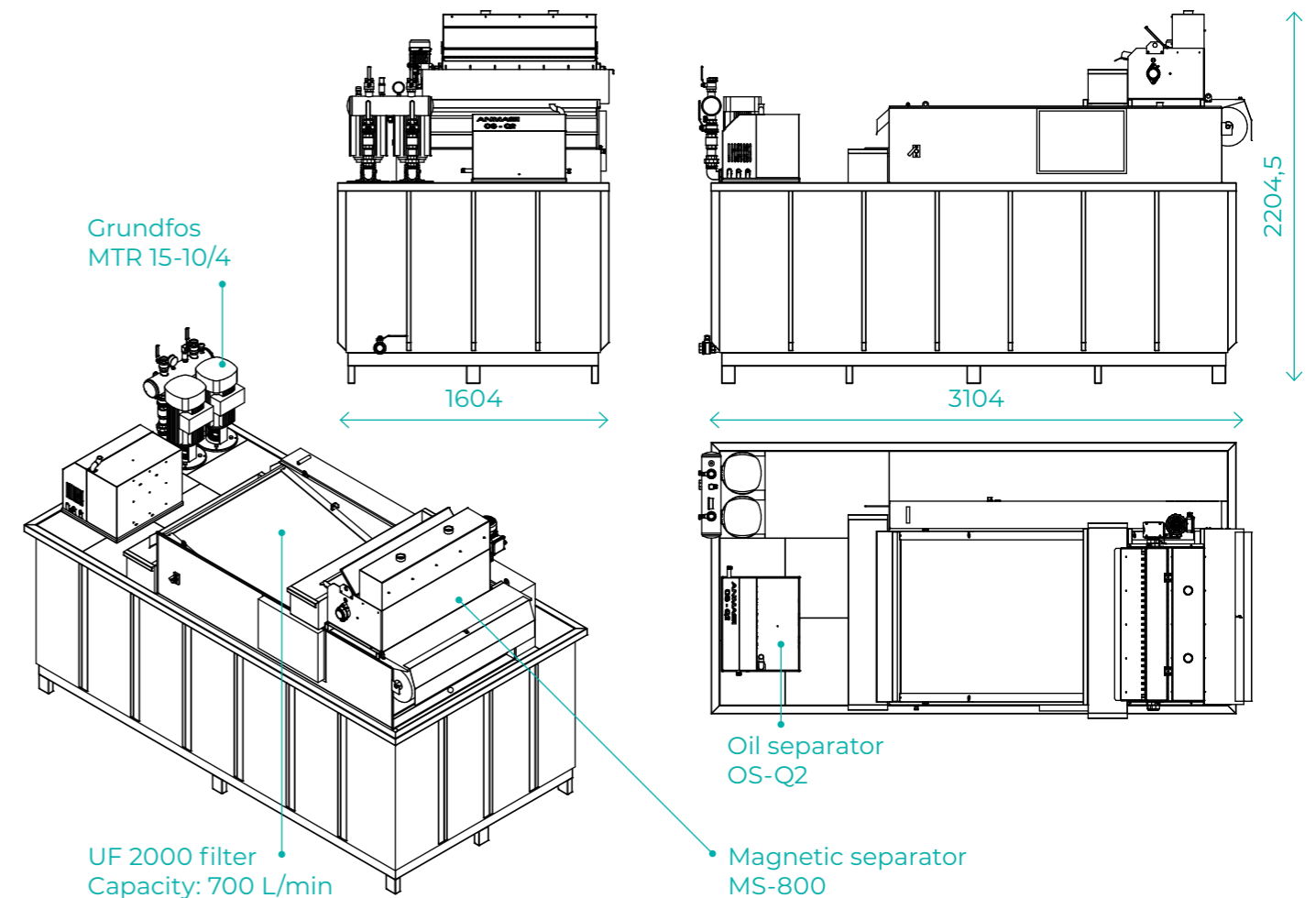

# MOBILE FILTER UNIT

A Mobile Filter Unit can easily be moved to and between the individual machines in a production. It is easy to connect and operate. With the Mobile Filter Unit we separate waste oil and particles from process fluids.

With a Mobile Filter Unit filtration is easy, mobile and efficient. The Mobile Filter Unit consists of a compact filter, as well as an oil separator and can filter both particles and oils from process fluids in one operation. The Mobile Filter Unit contains many of the functions included in a centralized system - united in a smaller and mobile version.

Additionally to the oil separator and band filter, the Mobile Filter Unit is equipped with a return pump, control cabinet, suction- and return hose and a canister for tramp oil collection.

## Applications:

- Coolant
- Process fluid
- Oil
- Water treatment
- Sewage



MODEL	MOBILE FILTER UNIT
Flow capacity	50 L/min
Separation chambers	4
Power supply	3x400V + N + PE - 50 Hz
Length	1080 mm
Width	685 mm
Height	1605 mm
Protection grade	IP54
Control current	24 VDC

✓ **Filtration and separation made mobile**

✓ **Extended process fluid lifespan**

Due to our efficient compact filter, we extend the durability of the emulsion, by removing unwanted particles.

✓ **Continuous draining of surface oils**

The oil separator ensures continuous draining of oils.

✓ **Extends the lifespan and lowers costs**

Efficient separation of oils and unwanted particles extends the lifespan of the process fluid and lowers costs.

✓ **Plug and play**

Easy to adjust and connect to different machines.

✓ **100% stainless steel construction**

Produced in AISI 304 / EN 1.4301.

✓ **CE - EU Machinery Directive**

The Mobile Filter Unit is produced in Denmark in conformity with the EU Machinery Directive.

# MACHINE CONNECTIONS

The machine connections are designed for our central filtration systems but can easily be implemented for similar systems from other manufactures.

It is very important to consider the type of machine connection when installing a filtration system. The right machine connection is just as important as the filtration system itself, and the installation must be carried out by trained personnel to avoid issues with the efficiency.

Our technical specialists determines in dialog with the customer which solution is most suitable depending on several factors such as contamination level, pump pressure, volume and space.

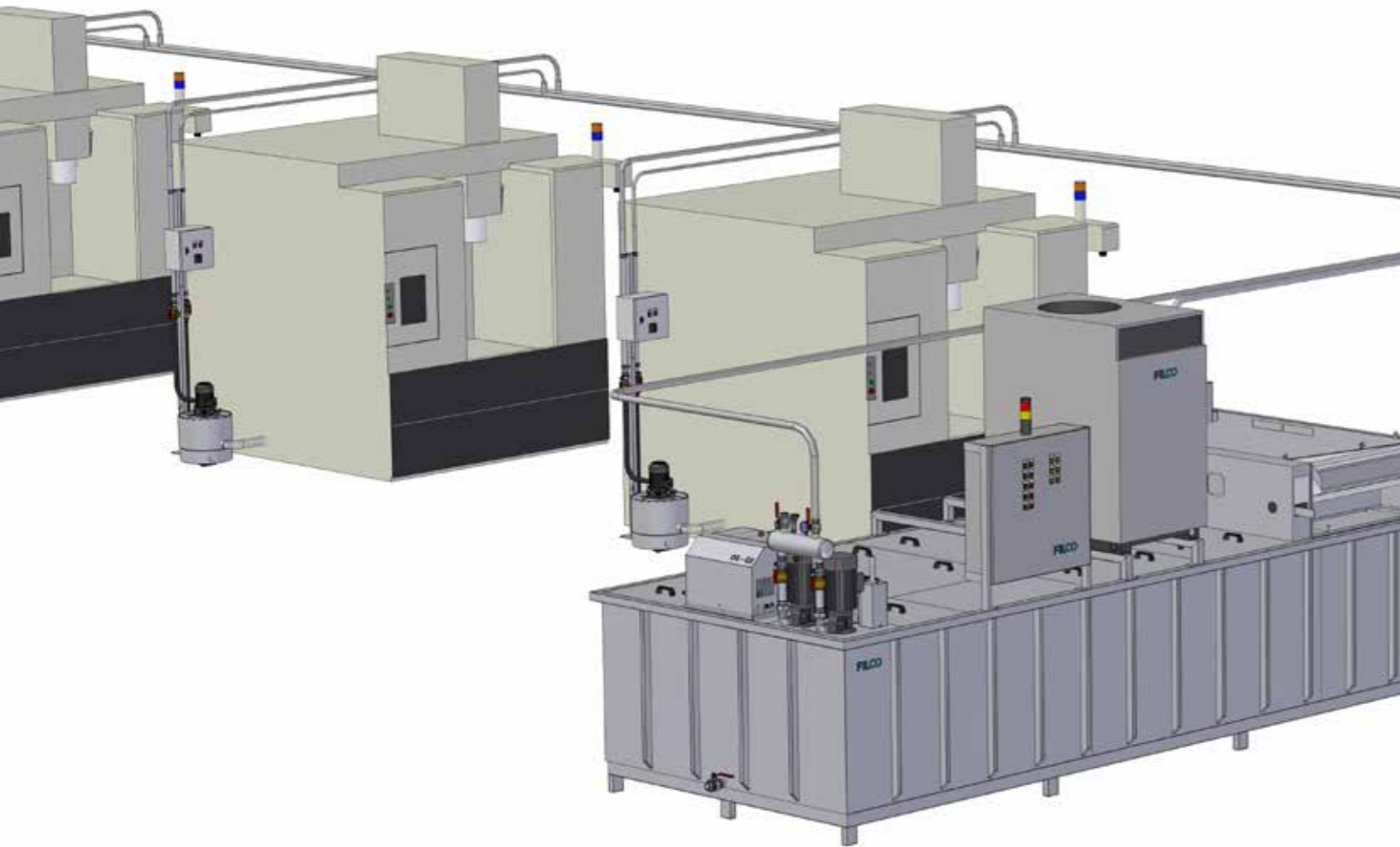

We manufacture and install two types of machine connections, which is used depending on customer application and economy.

The first type is our high-end external connection type CA with frequency-regulated pump, stainless steel self-cleaning Ø400 return vessel and capacitive level sensor.

The second type is our less expensive integrated connection type DIR, where the Ø200 pump vessel is placed directly inside the machine.



*This is our high-end external machine connection type CA which is necessary for some applications like when you are working with aluminum chips.*



*Integrated pump vessel type DIR CNC-Machine.*



*Integrated pump vessel type DIR Cleaning system.*

Our self-cleaning round pump vessel type CA with conical bottom avoids the accumulation of particles. The pump completely empties the entire vessel, making cleaning unnecessary. The design of the pump allows larger particles to pass through, making it suitable for machining processes.





# PISTON PUMP

Our specially developed piston pump with stainless steel housing and gear motor ensures a gentle treatment of the fluid to ensure optimal separation of free oils.

The piston pump is self-priming and slow running, which means that the fluid is not whipped around. It can handle many types of fluids ranging from low to high-viscosity. The piston pump is capable of dry running and can maintain a vacuum under various conditions.



MODEL	SP2
Flow capacity	2 L/min
Power supply	1x230V / 3x400V + PE 50 Hz
Protection grade	IP54



- ✓ **Unique piston pump**  
Our specially developed piston pump with stainless steel housing ensures efficient flow.
- ✓ **Self-priming**
- ✓ **Capable of dry running**
- ✓ **100% stainless steel construction**  
Produced in AISI 304 / EN 1.4301.
- ✓ **CE Machinery Directive**  
The piston pump is produced in Denmark in conformity with the EU Machinery Directive.

# COOLANT SAVER

Ensure oils and coolants aren't wasted with a coolant saver. Our coolant saver is manufactured and developed for continuous removal of small quantities of fluids from containers and tanks.



The coolant saver from FILCO is mounted parallel to a feed pump, so that the fluid feeds both the machine and the coolant saver. When the coolant passes through the coolant saver, a vacuum is created which suck up the fluid.

### The coolant saver recirculates oils and coolants and reduces waste:

- Capacity up to 20 liters per minute
- Parts that meet the medium are made of chemical-resistant materials
- Easy to clean
- Fully automatic operation
- Uses no power
- Simple and easy to install
- Inhibits bacterial growth
- Adjustable holder to protection of the hose in the swarf bin is included

MODEL	CS20
Connection	1/2" pipe
Outlet	1/2" hose
Suction hose	8 mm PU hose
Length	139 mm
Height	120 mm
Width	30 mm



- ✓ **Effective suction**  
The coolant saver ensures constant and reliable suction.
- ✓ **Flexible solution**  
Compact and flexible solution that can be easily installed in production.

- ✓ **User-friendly**  
Simple design that is easy to use and maintain in production.
- ✓ **100% stainless steel construction**  
The coolant saver is produced in AISI 304 / EN 1.4301 with accessories in other materials.

# FILTER PAPER

**We have a large stock of filter paper for direct delivery. Therefore you will experience no challenges with downtime and have no need for a large internal stock.**

Our paper types are offered in different types of material and sizes all in a very high quality as they are produced by leading manufacturers at factories in Western Europe.

The filter paper we offer is designed for high flow and long lifespan which ensures the lowest operating costs and the best degree of filtration.

Below you can read about our different types of filter paper.



- ✓ **Always on stock**  
FILCO always have a wide range of standard filter paper on stock.
- ✓ **High quality filter paper**  
We supply only the best filter paper, manufactured in reliable and sustainable materials.



## EcoPoly

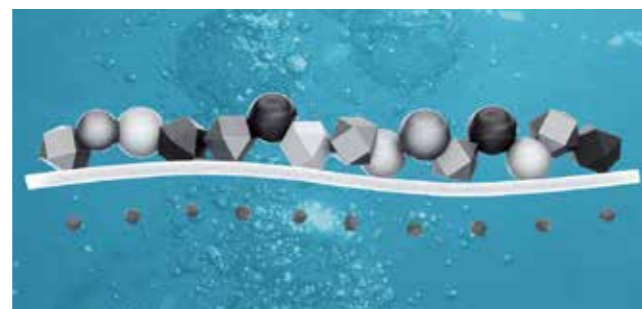

Durable filter paper which is spunbonded and made with polyester fibers.

This product is available in thicknesses from 20–150 g/m<sup>2</sup> and is suitable for large particles and high flow.

## UltraFleece

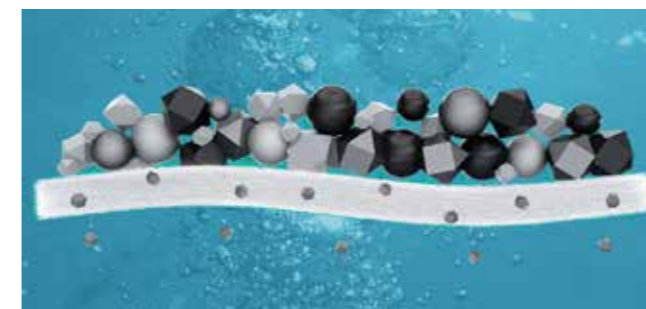

Durable filter paper consisting of cross-linked polyester fibers which is needle punched and thermally bonded.

Suitable for in-depth filtration and builds a good filter cake that ensures good filtration.

Available from 35–300 g/m<sup>2</sup> in thickness.

## UltraJet

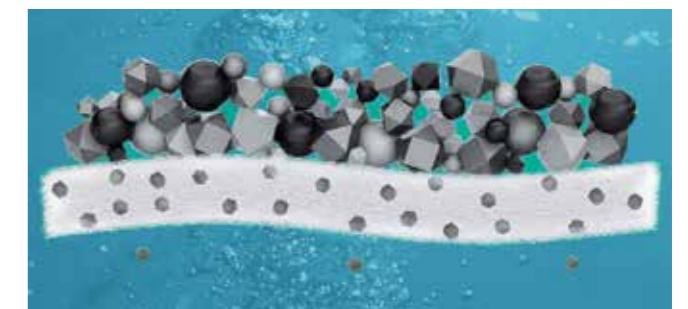

The best filter paper on the market where you will experience the highest performance in your filtration system. Incredibly durable filter paper consisting of hydroentangled polyester fibers mixed with microfibers. Experience the best in-depth filtration results with this type of filter paper which builds and maintains the best filter cake.

Available from 50–150 g/m<sup>2</sup> in thickness.

# CONTACT

## HEADQUARTER

### FILCO ApS

Sjorslevvej 33  
DK-8620 Kjellerup  
Denmark

Tel.: +45 8750 9899  
info@filco.dk  
www.filco.dk

Please contact us for more information about resellers worldwide. We have well-established sales agents all over Europe and partners in the United States, China and Canada.

## PRODUCTION PLANTS

### FILCO ApS

Sjorslevvej 33  
DK-8620 Kjellerup

### ANMASI A/S

Thorsvej 240  
DK-7200 Grindsted



**CE** "Every machine supplied by FILCO is produced in accordance with the CE – EU Machinery Directive"



With the  
environment  
in mind...

[filco.dk](http://filco.dk)